

# WiseRail®

## WiseCable® Rail Kits

AMERICAN COMPANY. AMERICAN TRADITION.  
AMERICAN PRIDE.™

Stainless Steel  
Cable Railing Infill for  
Unabstructed Views with  
**WOOD POSTS**

**DeckWise®**.com

Manufacturers of Hidden Deck Fasteners  
and Accessories



Decks come in all shapes and sizes, but there are only a few types of cable runs that go on those decks: face-mounted and through-the-post. The following illustrations represent several ways you can run cable on your deck. Every run will require a fitting that will act to tension the cable once installed. Depending on the length of the run, the tensioning device in the kit, and whether you plan to bend the cable through a corner, you will either be able to use a non-tensioning Push Lock or Pull-Lock on the other end or you will need to use a Push Lock tensioner on the other end.

## Why WiseRail® WiseCable® Railing Kits?

### Unobtrusive

- Views are not obstructed
- Decks, stairways, and interiors appear larger and more spacious

### Versatile

- Use indoors or outdoors

### Upscale appearance

- Clean sleek lines
- Attractive stainless steel
- Adds value to home

### Durable

- Virtually maintenance free with no painting or staining and no glass cleaner
- Weather-resistant type 316 marine-grade stainless steel



WiseCable® Cable Railing Kits are available in multiple combinations. Each kit is designed to accommodate a variety of installation situations, including stairs or angled runs, and runs through one or even two corners.

AMERICAN QUALITY  
**AMERICAN MADE**  
 AMERICAN PRIDE™





**The VIP Run**  
 You will see "Run #1" on each drawing, it is the View Run — the most important run and most visible of all your runs.  
 It is the Run on which you want to have the least interference with the view, so you always start with that run and build around it.

## Framework for Cable Railing

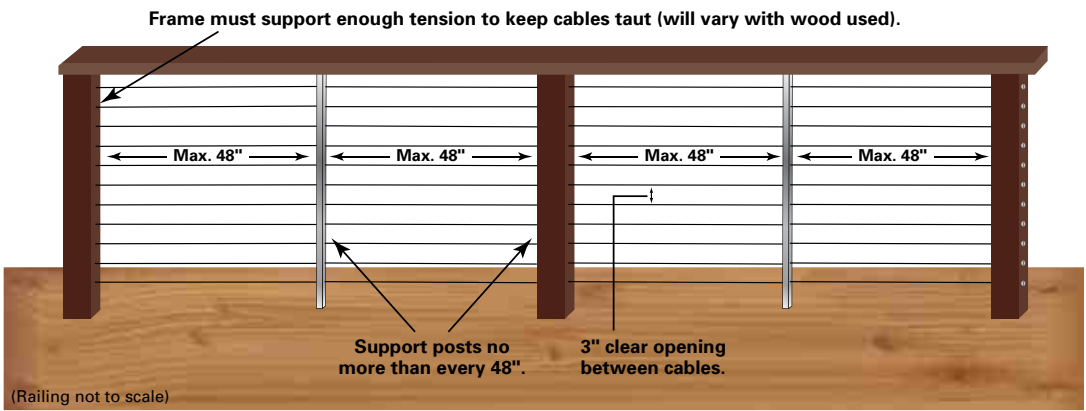

### Wood Posts

For wood posts a minimum 4x4 (3½"-square) post is required to keep the post from bending when the cables are tensioned. You will need a top rail, and we recommend that it be reinforced with a support such as a 2x4 on end under the top rail. End posts must be securely mounted to the deck to prevent the post from coming loose when the cables are tensioned. A bottom rail helps distribute the force away from the bottom of the post, but is not required.

### Intermediate posts between end and corner posts

To keep the cable from spreading beyond IBC code requirements, we recommend that the cable be supported in some manner no more than every 48" along its run. Intermediate posts, through which the cable is strung, act as supports for the cable. To avoid having to use more intermediate posts than is structurally necessary, a thin metal cable brace with holes for the cables to pass through can be used to support the cables (see illustrations). A typical cable brace is either ¾" x ¾" aluminum tube or ¼" thick by 1" wide stainless steel flat bar and is ordered separately.

### Cable spacing on posts

We recommend that you space the cables with no more than a 3" clear span between the cables (see illustrations). For example, if you are using 1/8" diameter cable, you would drill your holes on center no more than 3-1/8" apart.

# WiseRail® WiseCable® Stainless Steel Cable Rail

## Why Cable Railing?

### Easy to install

- Pre-assembled kits come complete, ready to install
- No special tools needed for installation

### Design flexibility

- Kits work with wood posts and wood posts with 4-1/2" composite sleeves
- Invisible fittings hide inside the wood posts, or streamlined for external fittings
- Standard lengths 5' to 50', trim to size
- For new or retrofit applications



**10-year warranty**

## How they work:

Every kit features a Push Lock and pull-lock fitting which, do not require any special tools for installation.

WiseRail® WiseCable® hardware is designed specifically for use with cable railings — it has not been adapted from marine hardware. WiseCable® Railing Kits are designed especially for the do-it-yourselfer and professional contractor.



## Kit Combinations for Wood Posts

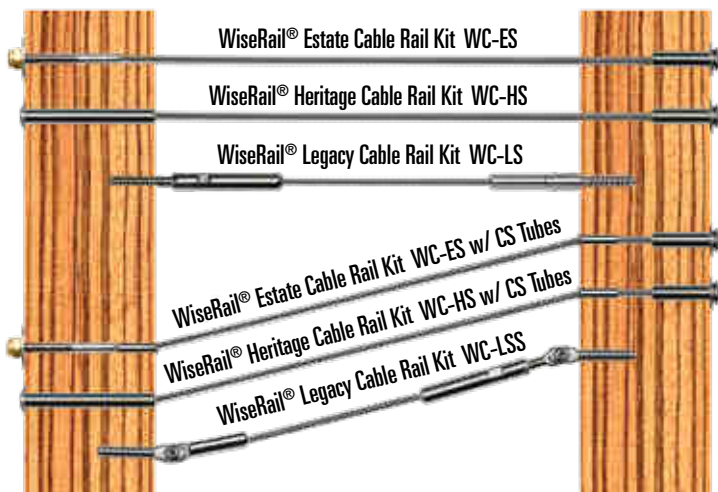

### For straight runs:

**Estate Series** (both ends through-the-post)  
Threaded stud to Pull-Lock.

**Heritage Series** (both ends through-the-post)  
3½" Invisiware Receiver to Pull-Lock.

**Legacy Series** (both ends face-mounted)  
Adjustable Body with Hanger Bolt to Push Lock Lag.

### For stairs, pitched runs:

**Estate Series** (both ends through-the-post)  
Threaded Stud to Pull-Lock.  
Post Protector Tubes used on both ends.

**Heritage Series** (both ends through-the-post)  
Invisiware Receiver to Pull-Lock using a Post Protector Tube.

**Legacy Series** (both ends face-mounted)  
Push Lock with Threaded Eye to Adjustable Body with Threaded Eye. Lag eyes on both ends.

# Wood Corner Posts

## Where Two Cable Runs Intersect

While you can offset cables on intersecting runs to use less expensive fittings, most people want all their cables to exist on the same plane, to give the impression that cables are continuous.

WiseCable® fittings are designed to be able to reside within the same post in many configurations.

Below are some examples of how your kit components work together.

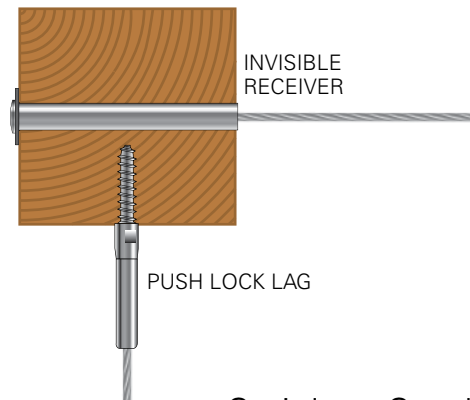
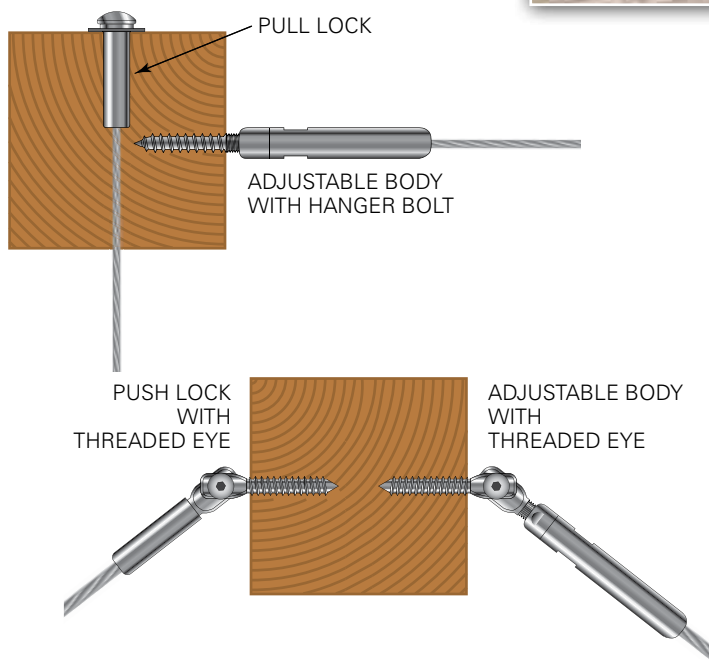

## Stainless Steel Post Protector Tube

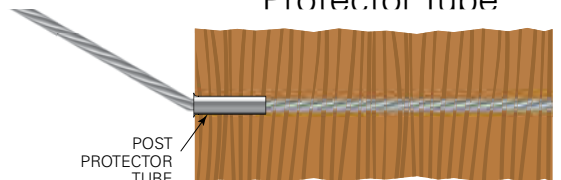

## Continuing a Cable Run Through a Corner

When taking WiseCable® railing through a corner, do not bend the cable past 45° at any time. If turning 90°, a 2-step turn using a double corner post configuration is required, as illustrated. For wood frame cable runs with up to 90° of turn, kits with single tensioners are sufficient. If going through corners totaling more than 90°, you will want to use a kit with tensioners at both ends.

Corners require two posts because the cable itself, being rigid, will not cooperate in bending cleanly through a single post. When you go through a corner post, you will need to prevent the cable from slicing into the wood as it exits the post on an angle by using a post protector tube.

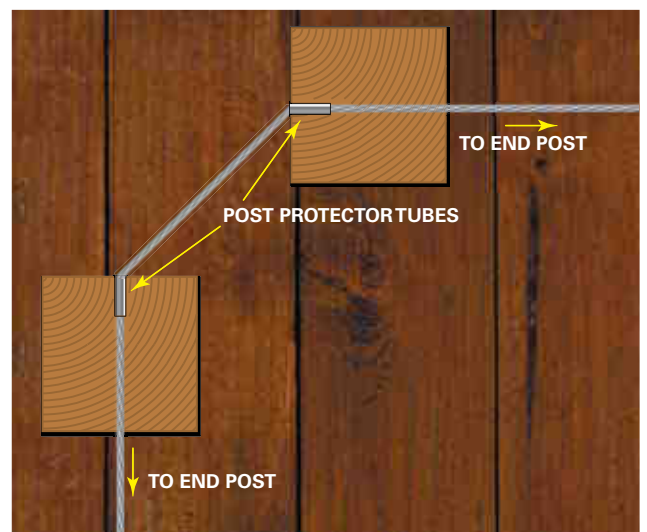

# Through-the-Post Mount for Wood Posts

## WiseCable® Heritage WC-HS



### Straight Cable Runs and Cable Runs Through One Corner

Decks 1 and 2 (below) have dedicated end posts for each run, and the posts are situated such that the back side of the posts are all accessible, meaning you can use a through-the-post configuration. This is both the most economical solution and where the fittings are least visible.

The tensioning device is a 3½" long Invisiware receiver, which installs through the wood post on one end. A Pull Lock fitting is installed through the other end.

When taking cable railing through a corner, do not bend the cable past 45° at any one time. If turning 90°, a 2-step turn using a double corner post configuration is required as illustrated in Deck 2.

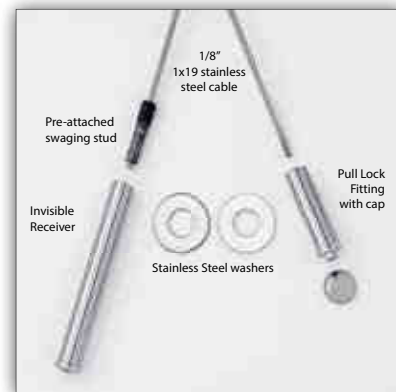

House

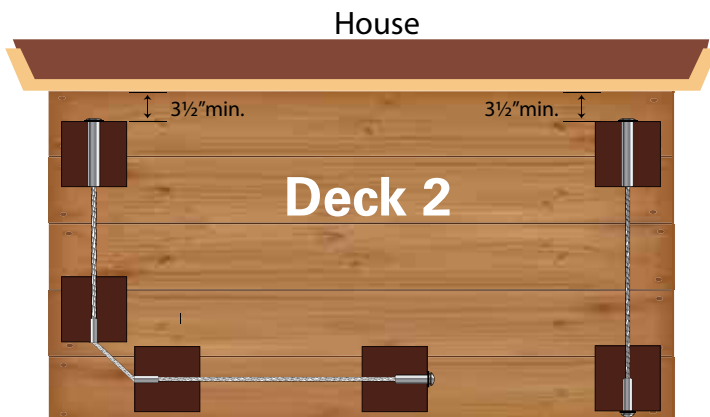
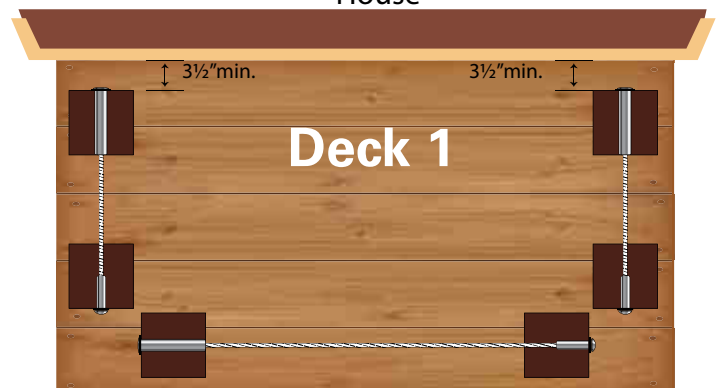

For post protector tubes (used with wood posts), see Tools and Essentials section.

#### Tools needed for WiseCable® Heritage Series:

- 5/32" drill bit if 1/8" cable
  - 29/64" drill bit for Receiver and Pull-Lock installation
  - 3/16" hex wrench for tensioning Receiver
  - Cable cutting tool
- If using post protector tubes, 1/4" drill bit

# Through-the-Post Mount for Wood Posts

## WiseCable® Heritage WC-HS

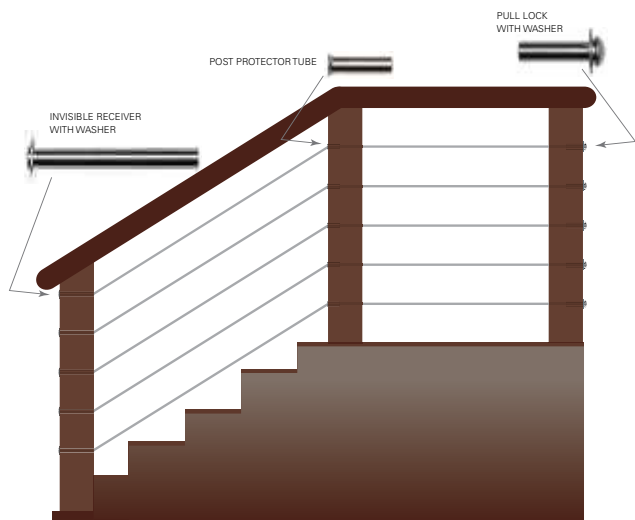

For post protector tubes (used with wood posts), see Tools and Essentials section.

WiseCable® Heritage 1/8" Dia.	
Cable Length	4x4 Wood Post
	MFG#
5 ft.	WC-HS-05
10 ft.	WC-HS-10
15 ft.	WC-HS-15
20 ft.	WC-HS-20
25 ft.	WC-HS-25
30 ft.	WC-HS-30
40 ft.	WC-HS-40
50 ft.	WC-HS-50

## Cable Runs on a Pitch

The cleanest approach to running cable on a pitch is to drill through both end both posts on the square (NOT at the angle of the stairs). No beveled washers necessary. Only intermediate posts need to be drilled on the angle of the stairs.

The tensioning device is a 3½" long Invisiware® Receiver, which installs through the wood post on one end. A Pull-Lock fitting is installed through the other end with a post protector tube (CS-TUBE), ordered separately. The WiseCable® Heritage Series can be used to go up a stair and across a landing by inserting post protector tubes in the break-over post. The tube will prevent the cable from carving a groove into your post where it exits at an angle.

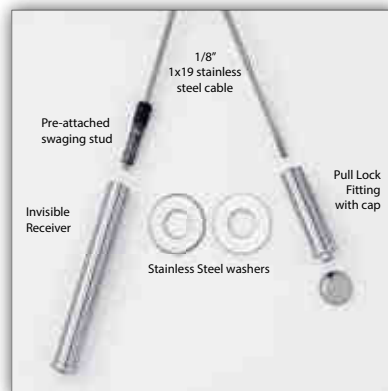

### Tools needed for WiseCable® Heritage Series:

- 5/32 drill bit if 1/8" cable, 7/32 if 3/16" cable
  - 29/64 drill bit for Receiver and Pull-Lock® installation
  - 3/16 hex wrench for tensioning Receiver
  - Cable cutting tool
- If using post protector tubes, 1/4 drill bit

## WiseCable® Legacy WC-LS

### Straight Cable Runs and Cable Runs Through One Corner

Deck 1 (below) has only one end post at the corners. The posts next to the house butt right up to it so the back sides of those posts are not accessible. Run #1 is still through-the-post, so it will take a WiseCable® Heritage or the economical WiseCable® Estate series kit.

Runs #2 and #3 connect to the face of the corner post going back toward the house to keep the cables on the same plane. They will use a WiseCable® Legacy LS Series and also connect to the face of the posts next to the house as well.

The tensioning device is an Adjustable Body with Hanger Bolt, which lags into the wood post on one end. A Push Lock Lag is lagged into the other end.

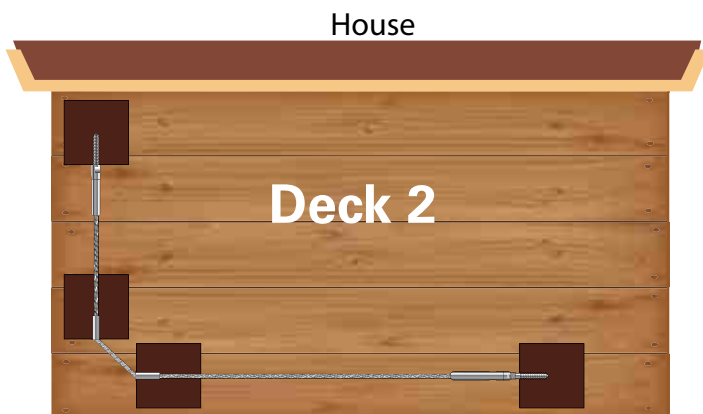
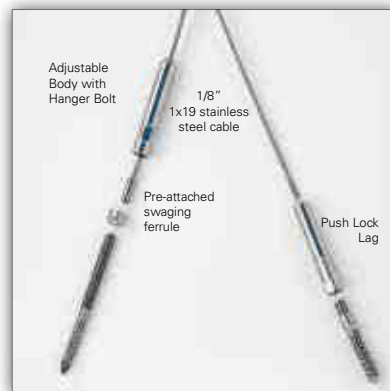

For post protector tubes (used with wood posts), see Tools and Essentials section.

#### Tools needed for WiseCable® Legacy LS Series:

- 5/32" drill bit if 1/8" cable, 7/32" if 3/16" cable
- 3/16" Hex wrench for tensioning Receiver
- If soft wood (Common Redwood), 7/32" drill bit; if hard wood (Common Douglas Fir), 15/64" drill bit for Adjustable Body with Hanger Bolt installation
- 1/4" wrench for turning Hanger Bolt
- 9/32" drill bit for Push Lock Lag installation
- 7/16" wrench for tensioning Adjustable Body and tightening Push Lock Lag
- 3/8" wrench for Push Lock Stud
- Cable cutting tool
- If using post protector tubes, 1/4" drill bit

When taking cable railing through a corner, do not bend the cable past 45° at any one time. If turning 90°, a 2-step turn using a double corner post configuration is required as illustrated in Deck 2.



## WiseCable® Legacy WC-LLS

### Cable Runs on a Pitch

Top posts are often corner posts, which may require the stair run to connect to the face of the post. The top and bottom of the cable run would be connected perpendicular to those posts, and only the intermediate posts would be drilled on the angle for the cable to run through.

The tensioning device is an Adjustable Body with Threaded Eye, which attaches via a mounting screw to the lag eye, threaded tab, or extended length lag eye, depending on the kit. A Push Lock with Threaded Eye attaches the same way to the other end.

The WiseCable® Legacy LSS Series can be used to go up a stair and across a landing by inserting post protector tubes (order CS-TUBE separately) in the break-over post. The tube will prevent the cable from carving a groove into your post where it exits at an angle.

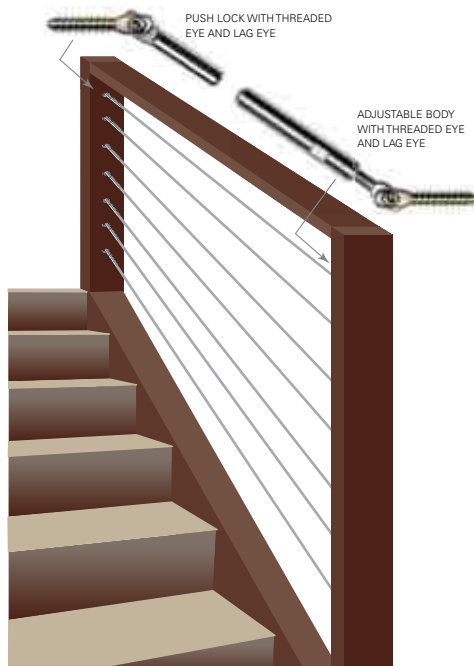
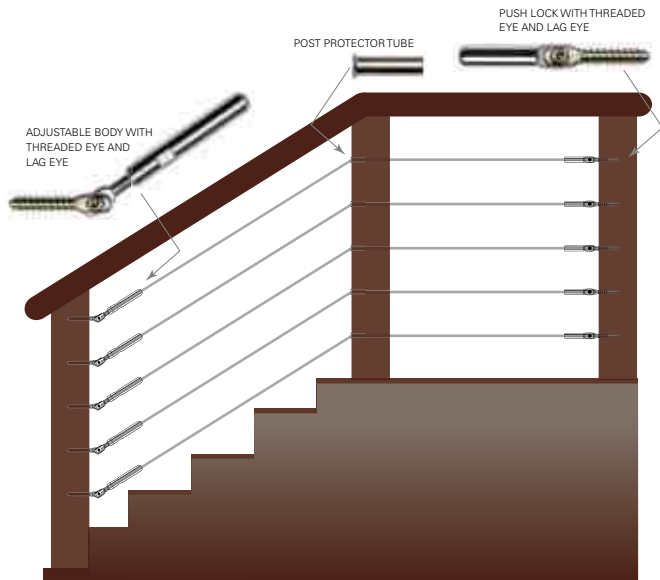

WiseCable® Legacy 1/8" Dia.	
Cable Length	4x4 Wood Post
	MFG#
5 ft.	WC-LS-05
10 ft.	WC-LS-10
15 ft.	WC-LS-15
20 ft.	WC-LS-20
25 ft.	WC-LS-25
30 ft.	WC-LS-30
40 ft.	WC-LS-40
50 ft.	WC-LS-50



#### Tools needed for WiseCable® Legacy LSS Series on stairs:

- 5/32" drill bit if 1/8" cable, 7/32" if 3/16"
- 7/32" drill bit for Lag Eye installation
- 7/16" wrench for tensioning Adjustable Body
- 5/32" hex wrench to tighten mounting screws
- Cable cutting tool
- If using post protector tubes, 1/4" drill bit

# Through-the-Post Mount for Wood Posts

## WiseCable® Estate WC-ES

### Straight Cable Runs and Cable Runs through One Corner

A through-the-post configuration is the only scenario in which the economical threaded stud kits may be used. The threaded stud kits are very economical, but the threaded studs are a basic, functional fitting, not a hide-in-the-post solution. A brass hex nut and some metal thread (both covered by an end cap) will extend beyond the back of the post on one end. A Pull-Lock fitting is installed through the other end.

The tensioning device is a 2-7/8" long threaded stud which installs on the back side of one end post, as shown in Deck 1.

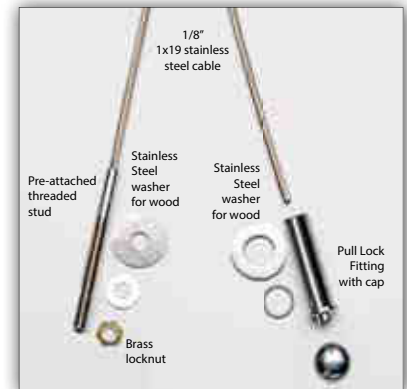
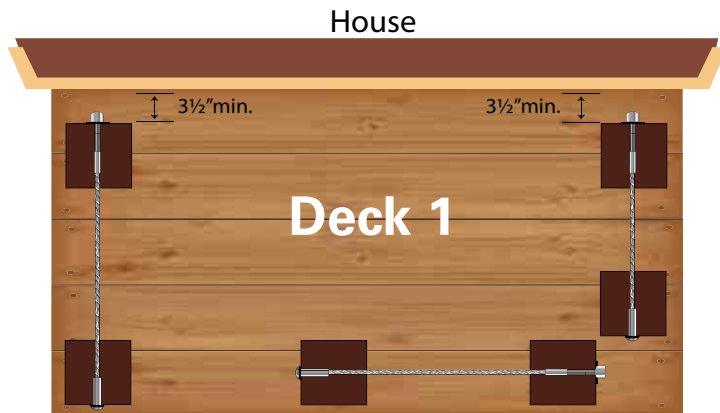

When taking cable railing through a corner, do not bend the cable past 45° at any one time. If turning 90°, a 2-step turn using a double corner post configuration is required as illustrated in Deck 2.



For post protector tubes, see Tools and Essentials section.

#### Tools needed for

#### WiseCable® Estate Series:

- 5/32" drill bit
- 9/32" drill bit for threaded stud installation
- 29/64" drill bit for Pull-Lock installation
- 7/32" wrench for holding the stud
- 7/16" wrench for tightening jam nuts
- Cable cutting tool
- If using post protector tubes, 1/4" drill bit

WiseCable® Legacy 1/8" Dia.	
Cable Length	4x4 Wood Post
	MFG#
5 ft.	WC-ES-05
10 ft.	WC-ES-10
15 ft.	WC-ES-15
20 ft.	WC-ES-20
25 ft.	WC-ES-25
30 ft.	WC-ES-30
40 ft.	WC-ES-40
50 ft.	WC-ES-50

# Through-the-Post Mount for Wood Posts

## WiseCable® Estate WC-ES

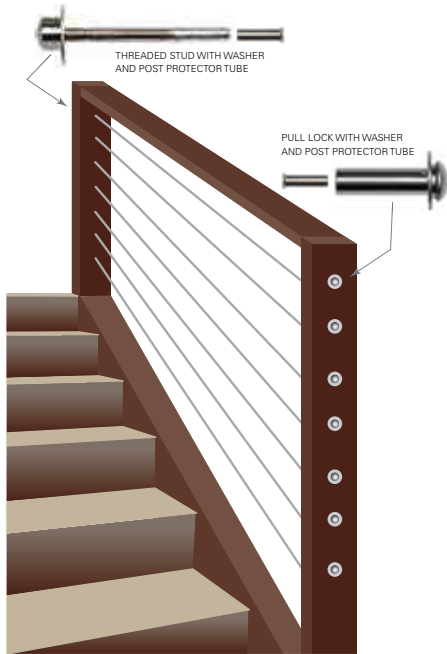

WiseCable® Legacy 1/8" Dia.	
Cable Length	4x4 Wood Post
	MFG#
5 ft.	WC-ES-05
10 ft.	WC-ES-10
15 ft.	WC-ES-15
20 ft.	WC-ES-20
25 ft.	WC-ES-25
30 ft.	WC-ES-30
40 ft.	WC-ES-40
50 ft.	WC-ES-50

### Cable Runs on a Pitch

The tensioning device is a 2-7/8" long threaded stud which installs on the back side of one end post. A brass hex nut and some metal thread (both covered by an end cap) will extend beyond the back of the post on one end. A Pull-Lock fitting is installed through the other end. The WiseCable® Estate Series can also be used in a stair-to-landing application with post protector tubes.

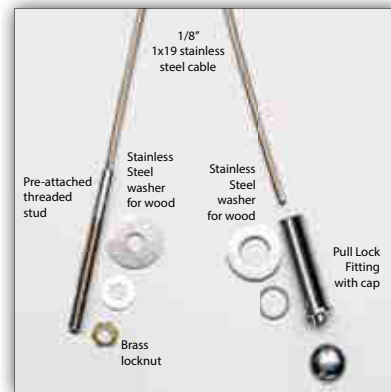

#### Tools needed for WiseCable® Estate Series:

- 5/32" drill bit
- 9/32" drill bit for threaded stud installation
- 29/64" drill bit for Pull-Lock installation
- 7/32" wrench for holding the stud
- 7/16" wrench for tightening jam nuts
- Cable cutting tool
- If using post protector tubes, 1/4" drill bit

# Face Mount for Wood Posts with Composite Sleeves

## Straight Cable Runs

Deck 1 has wood posts with composite sleeves. For sleeved posts, the recommended approach is face-mount for the best finished look. Since Deck 1 has only one end post at the corners, there is no bending of the cable through those posts. Each run must be start and stop. All three runs use the same kit.

**For wood posts with composite sleeves having an outside diameter of 4-1/2" or less, use the standard WiseCable® Legacy LS Series:**

The tensioning device is an Adjustable Body with Extended Length Hanger Bolt, which lags into the wood post on one end. A Push Lock Extended Length Lag is lagged into the other end.

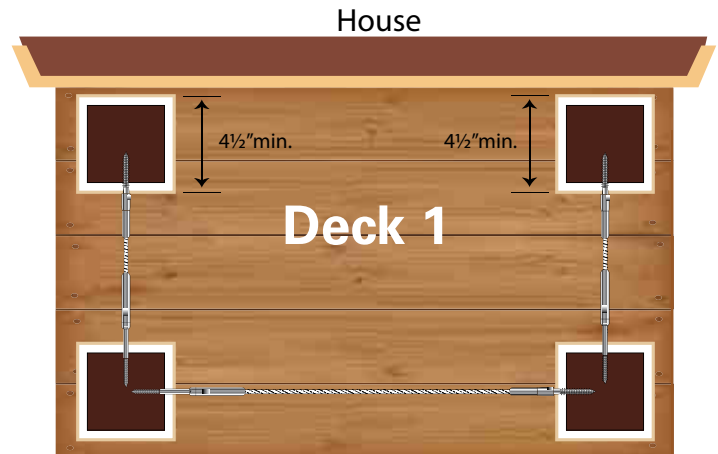

## Kit Combinations for Wood Posts with Composite Sleeves

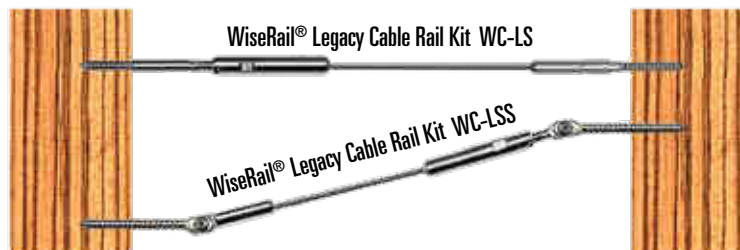

Outside diameter of the composite sleeve must be 4-1/2" or less to use the WiseCable® Legacy LS Series.

For wood posts with composite sleeves having an outside diameter greater than 4-1/2", call for special ordering.

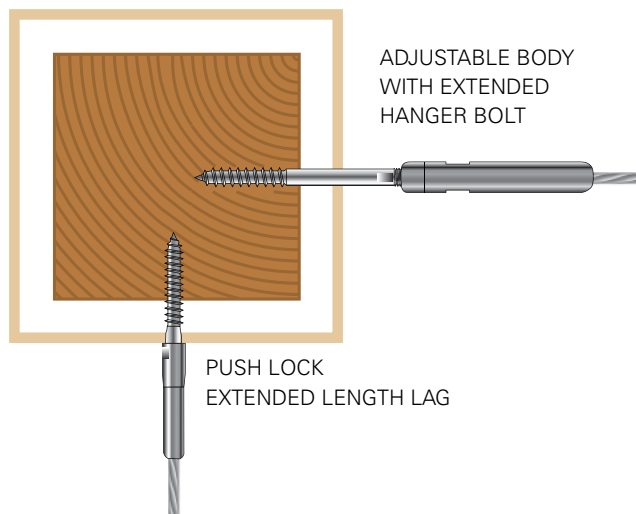

## Stainless Steel Post Protector Tube

The post protector tube is inserted into a wood post where the cable enters/exits the post at an angle to keep the cable from biting into the wood. **Order: WC-CS-TUBE-4**

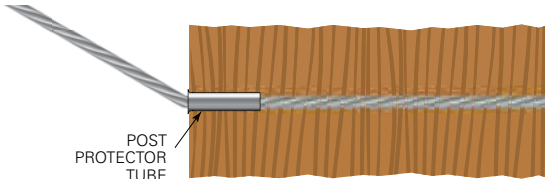

## Cable Release

For 1/8" Push-and Pull Locks only. Releases cable from Push Lock and Pull Lock type fittings before cables are tensioned. **Order: WC-PL-KEY**



## Stainless Steel Crown End Cap

Stainless Steel End Cap is elegant and durable, these end caps will add a finished look. **Order: WC-HS-CAP-10**



## Cut-off Tool

Used to cut cable flush with the end of Pull Lock fittings, and to cut excess threads off stud-type tensioners. Includes mandrel and two cut-off wheels.

**Order: WC-CUT-OFF-WHEEL**



## Light-Duty Cable Cutter

For burr-free cutting of cable.

**Order: WC-HIT-HWC6**



## Anodized Aluminum Cable Brace

3/4" x 3/4" tube, 42" long for cutting down to any size rail height. Holes pre-drilled at 3-1/8" on center, 13 holes total. For use between structural posts to keep cables code compliant on level runs. Use cable brace plugs to attach to top and bottom rail or deck.

**Order: WC-CB-AA-42-P-13H**



## Anodized Aluminum Cable Brace for Stairs

3/4" x 3/4" tube, 42" long for cutting down to any size rail height. Comes undrilled so slots can be field-drilled to match cable array.

**Order: WC-CB-AA-42-P-S**



## Heavy-Duty Cable Cutter

For burr-free cutting of cable. For light-duty use to cut 1/8" cable, order C-7HIT (not pictured) To cut cable 1/4" diameter and under,

**Order: WC-HIT-HWC9**



## Cable Gripping Pliers

Locking pliers with machined jaws to grip the cable as you are tensioning the cable. Keeps the cable from turning and prevents damage to the cable when cable is being tensioned.

**Order: WC-PLIERS**



## Light Duty Hanger Bolt Driver

Use to install Adjustable Body with Hanger Bolt tensioners. Makes driving hanger bolts fast and easy.

**Order: WC-LD-BOLT-DRIVER**



# Designing A Wood Railing With Cable As An Infill

## Overview

There are eight considerations in designing a railing with cable infill:

1. Construction and location of your end posts
2. Configuration of any corners in your design
3. Location of intermediate posts
4. Location of additional cable supports
5. Cable diameter to use
6. Spacing of cables on your end post
7. Whether to cut cables and install fittings in the field, use factory-cut and swaged cables, or use retail kits

We will address these considerations in order.

### 1. Construction and location of your end (terminating) posts.

An end post is a post to which terminating cable ends are attached with tensioning or non-tensioning hardware. Considerable tension is applied to the end posts, when the cable is properly tensioned. A substantial end post is necessary to prevent the end post from bending which will cause the cables to sag. In wood, a minimum 4x4 end post is required. End posts must be securely fastened to the top rail and deck or other surface to prevent the post from coming loose with the forces applied through the tensioned cables.

Support members between end posts are also necessary. In wood, we recommend support members running between posts, such as a 2x4 secured to the inside of each post, so you are not relying on the shear strength of the nails or screws to support the tension applied to the end post.

### 2. Configuration of any corners in your design.

At corners or turns of more than approximately 45 degrees, it is best to terminate your runs in each direction with an end post (minimum of a nominal 4x4). The following illustrations demonstrate how this is done.

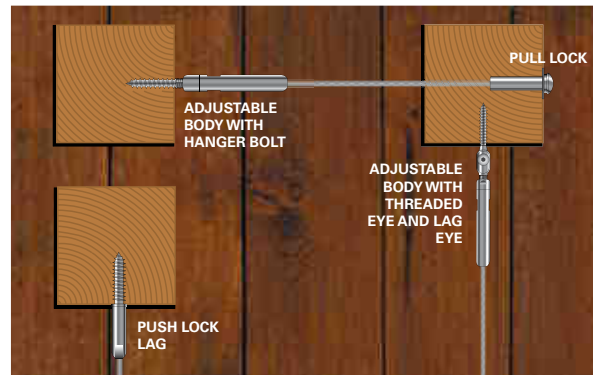

Frame must support enough tension to keep cables taut (will vary with wood used).

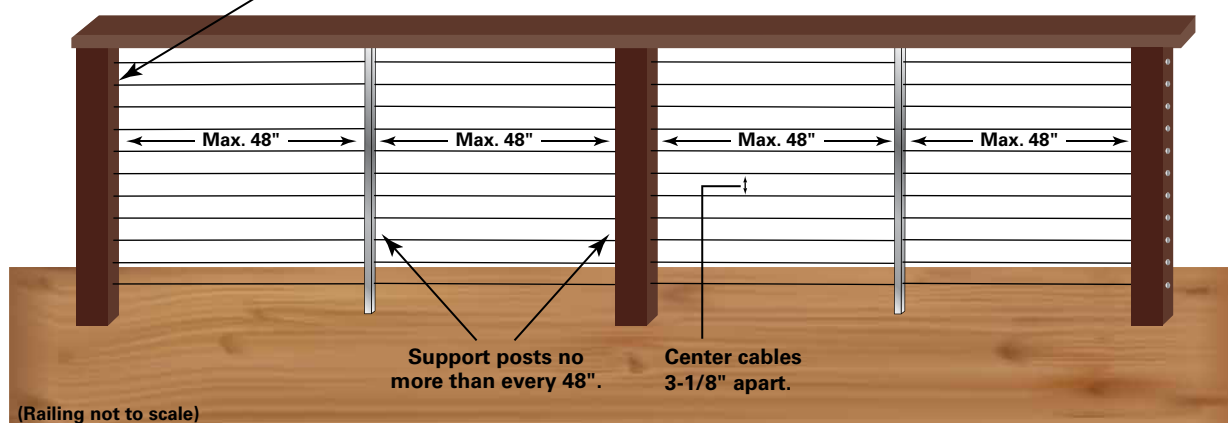

# Designing A Wood Railing With Cable As An Infill

A corner may be designed using two posts on the corner and running the cables between the posts as illustrated below.

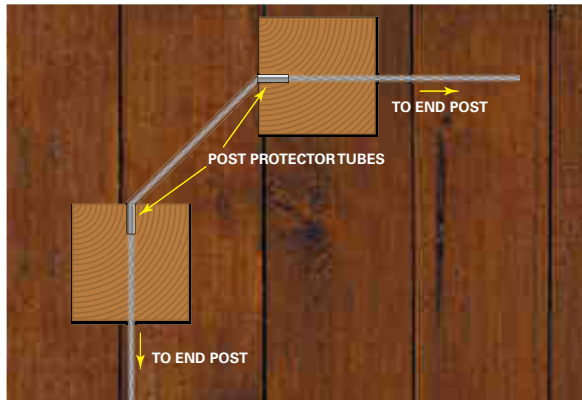

When going around a corner, the cable will often enter or exit the post at an angle. To prevent the cable from biting into the wood when it is tensioned, the wood in the post must be protected. Post protector tubes are available from the factory (see the Tools & Essentials on page 13 for order information).

The post protector tube is a flared length (3/4") of tube that is pushed into the hole for the cable, so the cable rests against it as opposed to the wood itself. The inside diameter of the tube is just large enough for the cable to pass through, so its use requires the non-swaged end of the cable to pass through the tube; no pre-swaged fittings will pass through the post protector tube.

On a turn of less than approximately 45 degrees, you can run your cables through a single post, but you will still need to protect the post where the cable enters or exits the post at an angle to prevent the cable from biting into the wood when it is tensioned.

### 3. Location of intermediate posts.

Intermediate posts (or mid-posts) are placed between end posts. An intermediate post runs from the top rail to the lower mounting surface and is a structural element. Intermediate posts should be placed at intervals between end or corner posts as frequently as necessary to meet building code requirements. An engineer or design professional should be engaged, if you are unable to otherwise determine intermediate post spacing.

Cable is strung through holes drilled in the intermediate posts, so intermediate posts also become supports for the cable between end posts.

With cable spaced vertically on centers as recommended below (see **No. 6**), we recommend that the cable be supported in some manner no more than every 48" along its run. The support can be provided by an intermediate post or it can be something thinner such as a 2x4 or a thin steel or aluminum cable brace (see **No. 4** below). (See the Tools & Essentials on page 13 for order information)

### 4. Location of additional cable supports.

Regardless of the amount of tension you apply to the cables, there will be some flex in the cable when it is installed. When the cables are spaced vertically on your end post as recommended in **No. 6**, we recommend that the cable be supported in some manner no more than every 48" along its run, to meet code requirements that a 4" sphere cannot pass through the cables.

As indicated, this support can be provided with intermediate posts or a lighter material acting as a cable brace. As with an intermediate post, a cable brace also runs between the top rail and the lower mounting surface, but its purpose is only to support the cable. It is not intended to be an element providing structural support to the railing.

Cable braces can be much thinner and, therefore, less obtrusive than posts, as their primary purpose is only to support the cable.

A 3/4"x3/4" aluminum tube, with holes drilled for the cables to pass through, makes an excellent cable brace. Both types of cable braces are available from the factory (see the Tools & Essentials on page 13 for order information).

# Designing A Wood Railing With Cable As An Infill

## 5. Cable diameter.

It is important to use 1x19 construction cable as a railing infill, because it is attractive, smooth to the touch, and designed to support loads in tension with minimal stretch.

The individual wires in 1x19 construction cable are much larger than those used in more flexible constructions. This makes the cable less prone to damage from abuse, and it is also the reason why strand does not stretch as much as other constructions.

We specify 316 Grade stainless steel because it is the most corrosion resistant commercially available

alloy used in manufacturing cable. WiseRail® hardware is made from 316 Grade stainless steel, so no material compatibility issues will arise when you use 316 stainless steel cable with our hardware.

For commercial railing, it is important to use at least a 3/16" diameter cable. Problems have been experienced with damage from abuse when 1/8" diameter cable has been used. Refer to the chart below for the minimum breaking strengths for type 316 stainless steel cable.

Call the factory for 3/16" cable special ordering.

### Cable Minimum Breaking Strengths

Cable Dia.	Minimum Breaking Strength (Lbs.) For Following Cable Constructions in Type 316 Stainless Steel		
	1x19	7x7	7x19
1/8"	1,780	1,360	1,300
3/16"	4,000	3,300	2,900
1/4"	6,900	5,500	4,900
5/16"	10,600	7,600	7,600
3/8"	14,800	11,700	11,000

NOTE: WiseRail® cable rail is only offered as 1x19, 316 Grade stainless steel, at 1/8" diameter. Hardware is designed for use in pedestrian guard-railings. For other applications, consult the factory for suitability.

**Chart is for informational purposes only.**

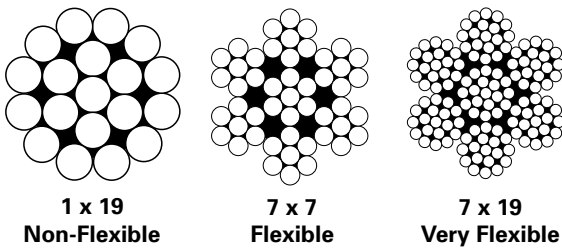

## 6. Spacing of cables on your end post.

Even though you use 1x19 construction cable and the cables are properly tensioned on a strong end post, there will be some flex in the cable when a load is applied.

The spacing of the cable on the end posts works together with the distance between points where the cable is supported, to minimize cable flex. The closer together the cables are spaced on the end posts, the longer the distance can be between cable support points. The reverse is also true.

We recommend that you space the cables with no more than a 3" clear span between the cables. Cable railing requires additional support (mid posts) every 4 feet. This ensures cable spans will have minimum deflection.

Weighing the desire to use as few cables as necessary with the need to minimize cable flex, we recommend maximum vertical spacing of the cables on your end posts be 3-1/8" on center.

To calculate cable spacing you must first measure from the deck top surface or bottom rail, to the bottom of your top rail. Then divide that number by the 3" cable spacing and subtract 1.

- **Example 1:** 30 inches between deck surface and bottom of the top rail:  $30 / 3 = 10$  and  $10 - 1 = 9$ . The requirement is 9 runs of cable.
- **Example 2:** 36 inches between deck surface and bottom of the top rail:  $36 / 3 = 12$  and  $12 - 1 = 11$ . The requirement is 11 runs of cable.

Our recommended cable spacing is 3-1/8" on-center running the length of each wooden post. For example, you will be using 1/8" diameter cable, you will drill your holes on center no more than 3-1/8" apart.

Any variance from these recommendations should be discussed with your architect, designer or inspector before you proceed.

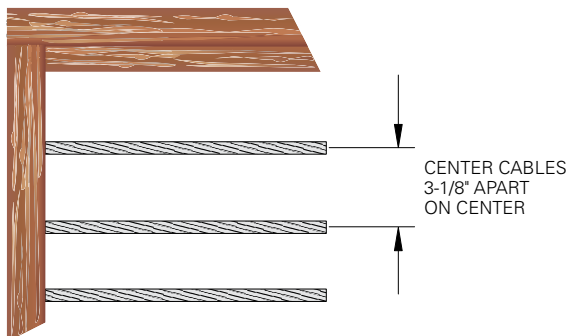



# Designing A Wood Railing With Cable As An Infill

## 7. Installing cable rail fittings in the field with factory-cut cables.

Our factory installs the swages and packages the cable cut to length and fittings as ready to install kits. Complete instructions are included with each kit.

### Factory Swaged Cable Rail Kits

Because the cables are cut and the fittings swaged by us, you do not need to use special swaging equipment. Although, some tools are helpful during the installation as shown on page 13.

Most WiseRail® hardware is designed to pass through holes in your intermediate posts that are drilled as little as 1/16" larger than the diameter of the cable. All installation instructions include appropriate drilling guidelines.

### WiseCable® Heritage WC-HS

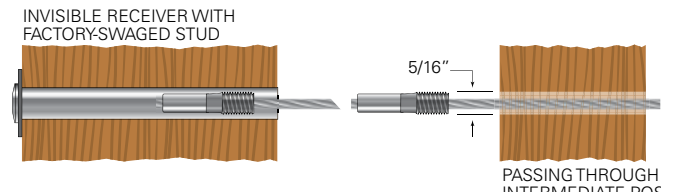

### WiseCable® Legacy WC-LS

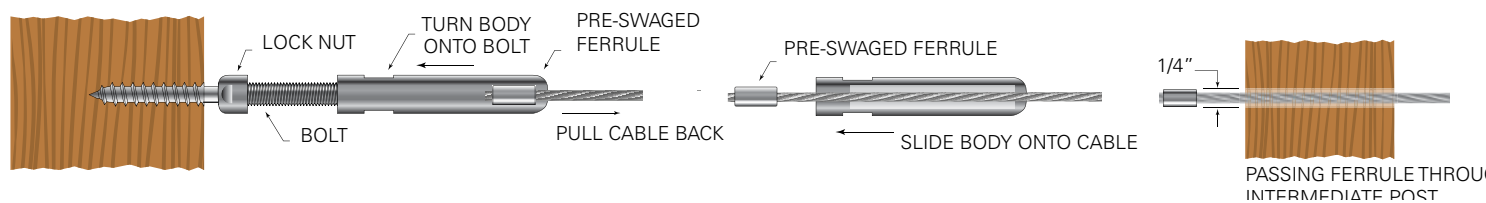

### WiseCable® Legacy WC-LLS

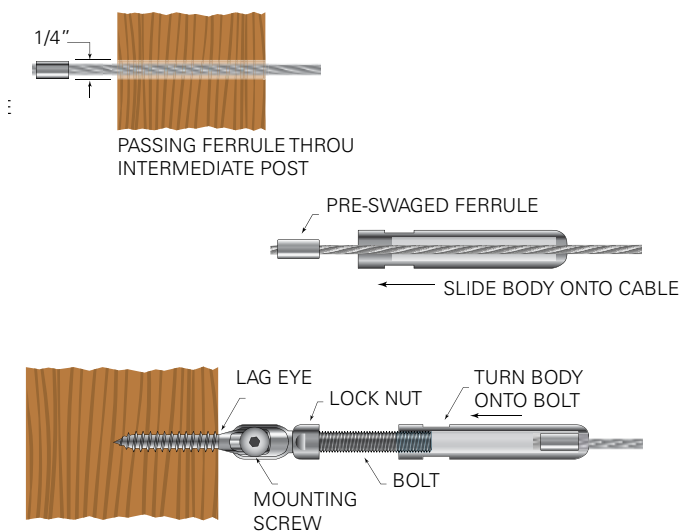

### WiseCable® Estate WC-ES

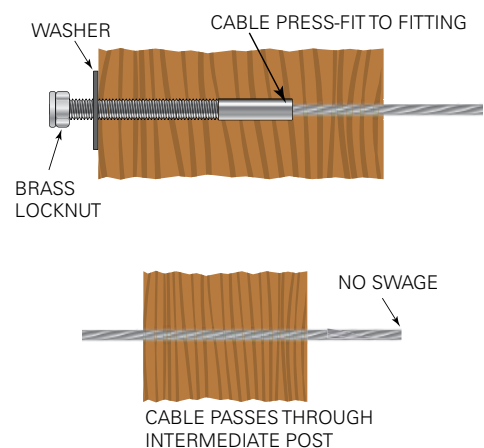

When the cable will not pass through any intermediate posts, any hardware can be used. You are not limited as to the fittings you can use.

# Designing A Wood Railing With Cable As An Infill

## A. Mounting hardware on your end posts.

If you are mounting hardware on two sides of your corner posts, then your corner posts are considered end posts for this discussion.

You will need to put tensioners on at least one end of each cable run. For outside to outside fittings, you will need up to 3-1/2" of space between the back of your end post and any structure in order to insert the fitting into the end post from the back side.

### Outside to Outside

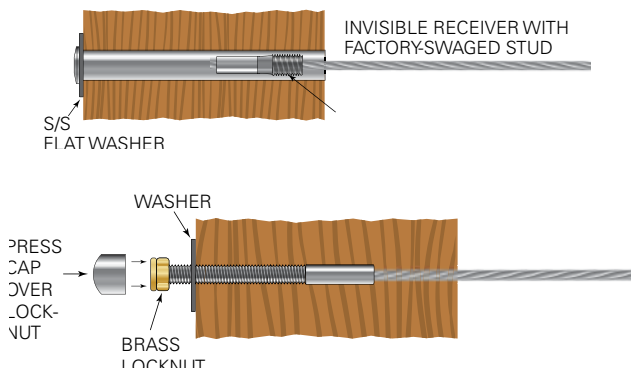

### Inside to Inside

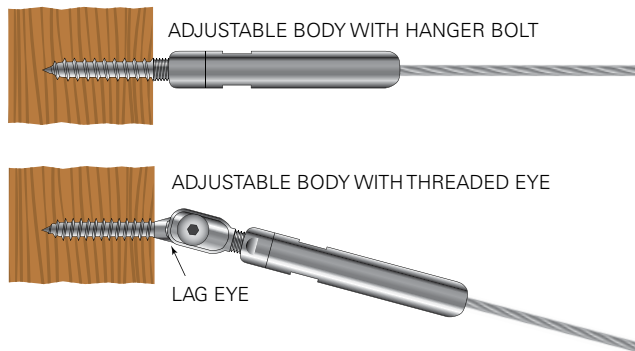

The other end of each cable run can be either a tensioner or a non-tensioning device.

Following are non-tensioning devices. With the Push Lock or Pull Lock fittings, you will need approximately 2-1/2" of space between the back of your end post and any structure to insert the fitting into the end post from the back side.

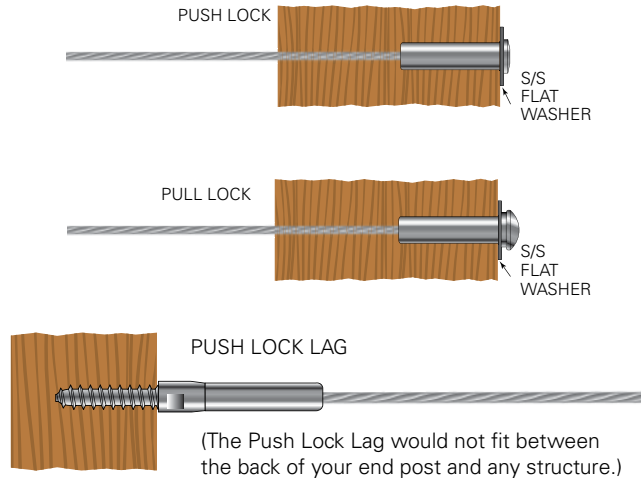

**B) How you wish to configure your corners (if applicable).** See No. 2. Configuration of any corners in your design for ways to treat your corners.

The following illustrations demonstrate how the hardware can be used on a single corner post. Not all combinations are shown here. If the hardware and cable run all the way through the post in one direction, you will need to use a hanger bolt end or hardware that is mounted to a lag eye for the perpendicular direction, as shown in the first four illustrations that follow.

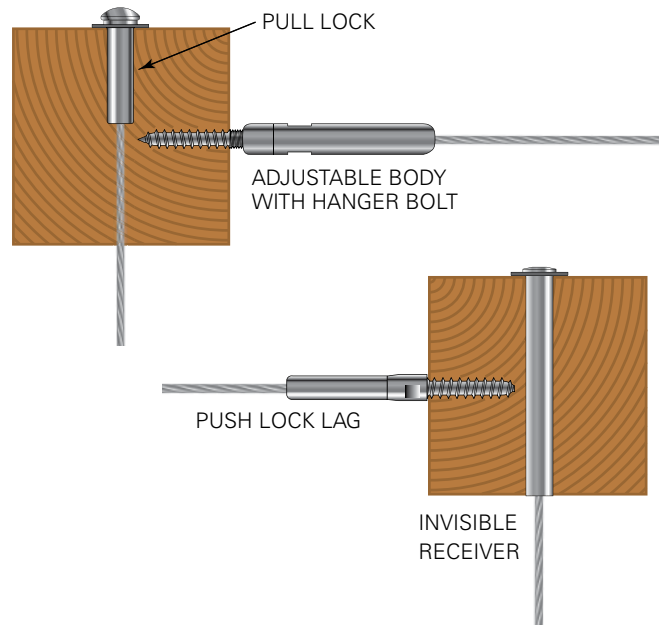

# Designing A Wood Railing With Cable As An Infill

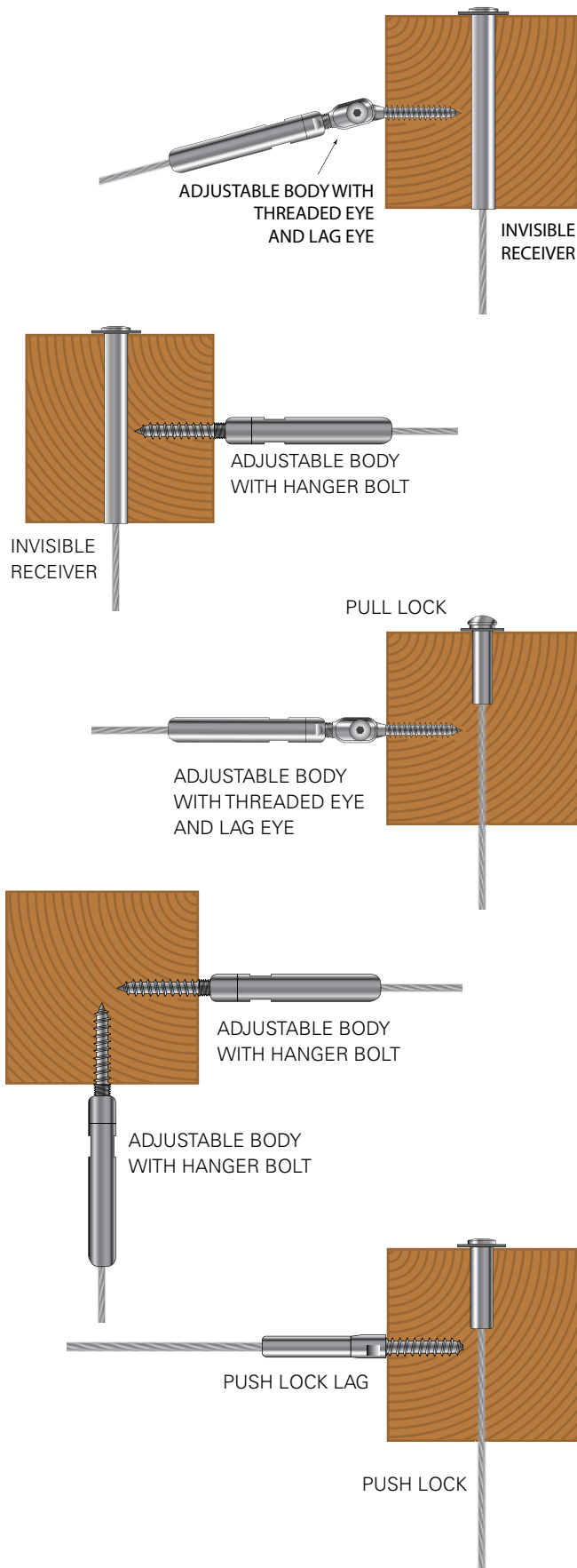

## C) Hardware used for stairs or angled runs.

You can use any of the articulating fittings in conjunction with a lag eye to accommodate stairs and runs that angle out of the end post.

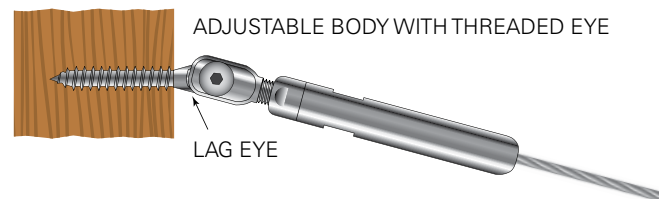

You can also use Invisible Receivers and Pull Locks on your 4x4 (3.5" square) end posts without having to drill your holes at an angle.

Invisible Receivers are less expensive than articulating fittings and do not require lag eyes and screws to mount them. When installed, they are hidden inside the end post to help preserve that special view. The Invisible Receivers are especially designed for 4x4 wood posts and can be an excellent choice for stairs and angled runs as well as straight runs.

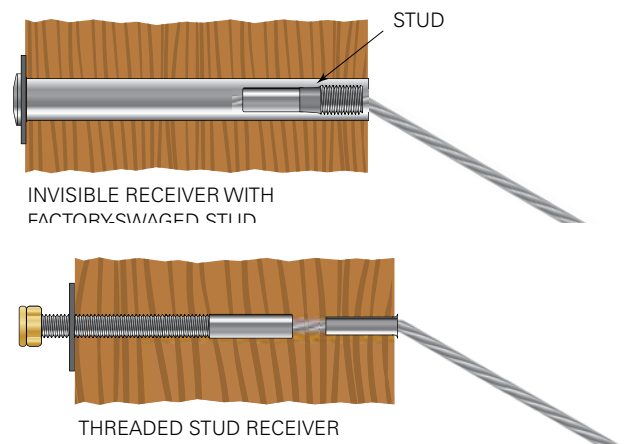

Pull Lock non-tensioners work well opposite the Receiver in stair and angled runs from wood posts. When coupled with a post-protector tube, they complement the Receiver while allowing the cable to be trimmed on site.

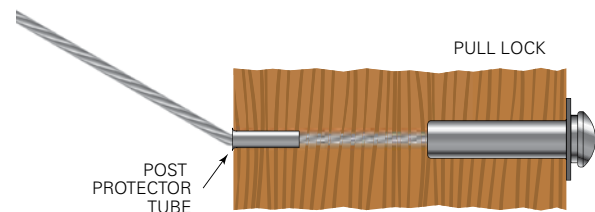

# Your Project

Make a top-down drawing of your project. Include railing lengths, end and corner post locations, stairs and any angles/turns your railing takes. Be sure to consider the following:

- What size post?
- What material (hardwood, composite sleeve)?
- If composite sleeve, what is the outside diameter when installed? (Minimum size is 4-1/2")
- What is the height of the railing?
- Are you using a bottom rail?
- Are you using single posts at corners or a double post configuration?
- Do you have 3 1/2" of space behind end posts to allow for installation of Receivers and Pull Locks?
- What diameter cable are you using (1/8")?

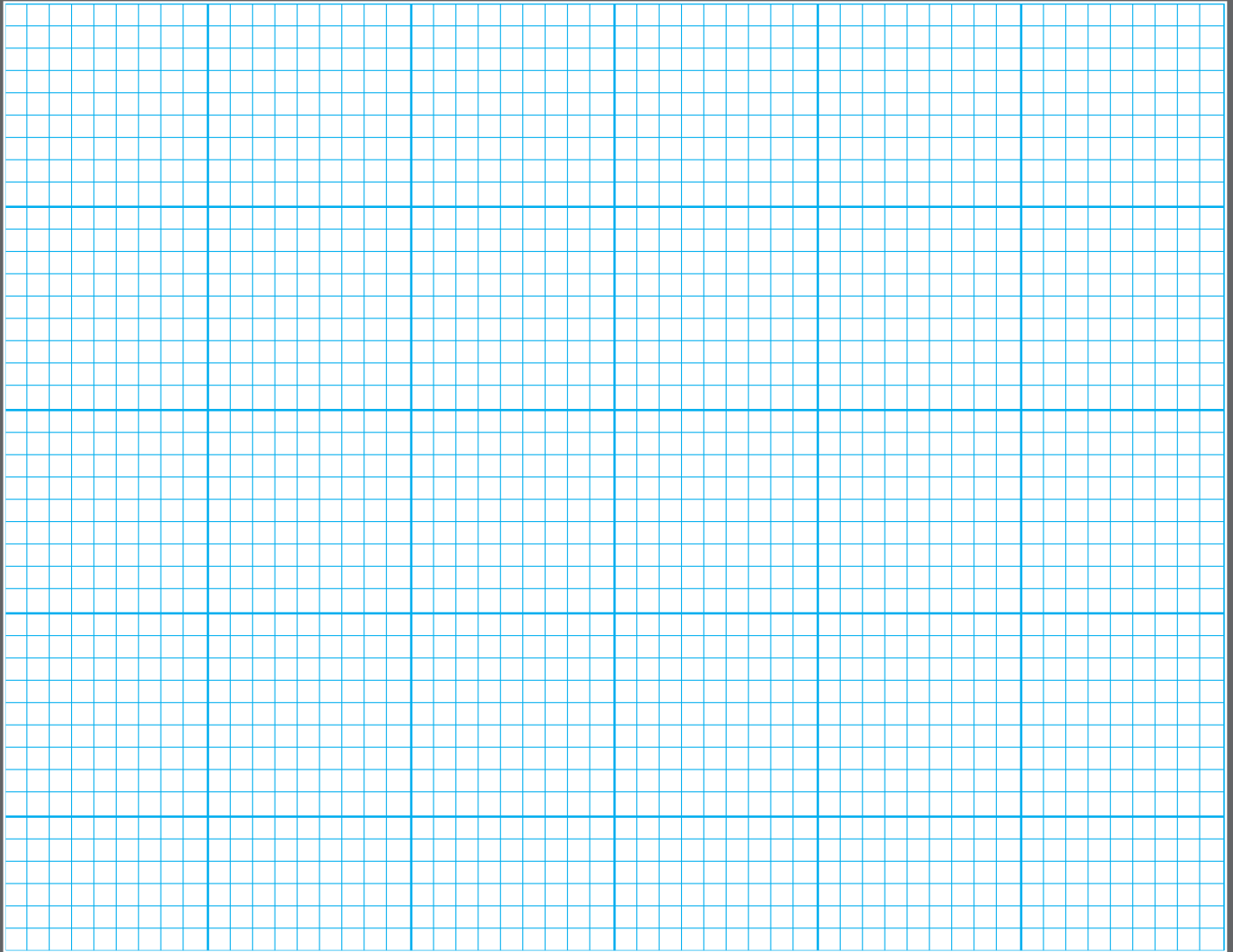

© 2017, DeckWise, The Ipe Clip Fastener Co., LLC. All rights reserved.

WiseRail® Cable Railing Kits distributed by:



Manufacturers of Hidden Deck Fasteners  
and Accessories

941-896-9851  
[www.DeckWise.com](http://www.DeckWise.com)

DeckWise®, The Ipe Clip® Fastener Company, LLC.  
2111 58th Ave. East • Bradenton, FL 34203

AMERICAN QUALITY  
**AMERICAN MADE**  
AMERICAN PRIDE™



